

*Conseil et service personnalisé*  
*Persönliche Beratung und Service ✓*

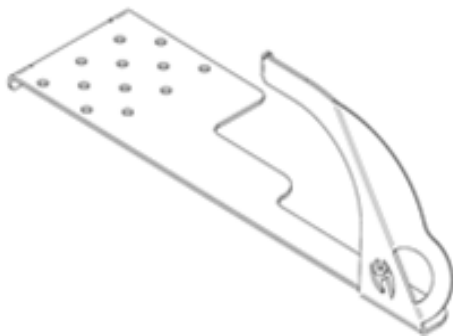

# Toiture en pente

## SDH-31, couleurs suivantes en stock à Sierre



RAL 7021

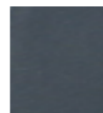

RAL 7004



RAL 8017

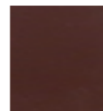

RAL 8004



## SDH-32, couleurs suivantes en stock à Sierre

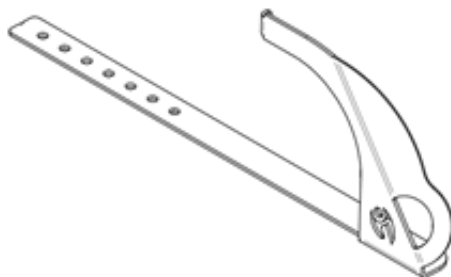

RAL 7021

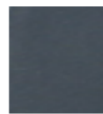

RAL 7004



RAL 8017

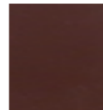

RAL 8004



## SDA-35, couleur suivante en stock à Sierre

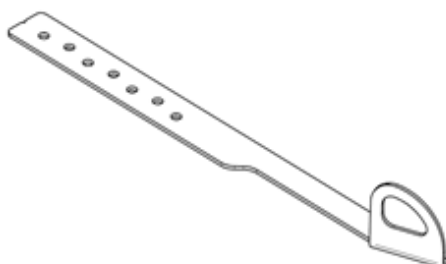

Inox V2A



# → Gamme de produits





## INNOTECH - Toiture en pente pour support bois, min. 8 x 10 cm

Emballage de 10 pcs

Art. Nr.	Désignation	Réalisation / Spécifications / Couleur	Couleur	Fr./pce
18.755	<b>SDH-31-A</b>	Crochet de service avec point d'ancrage	RAL 7021 Anthracite	<b>60.00</b>
18.756	<b>SDH-31-B</b>	Crochet de service avec point d'ancrage	RAL 8017 Brun	<b>60.00</b>
18.757	<b>SDH-31-G</b>	Crochet de service avec point d'ancrage	RAL 7004 Gris	<b>60.00</b>
18.951	<b>SDH-31-R</b>	Crochet de service avec point d'ancrage	RAL 8004 Rouge	<b>60.00</b>
18.758	<b>SDH-32-A</b>	Crochet de service avec point d'ancrage	RAL 7021 Anthracite	<b>58.00</b>
18.759	<b>SDH-32-B</b>	Crochet de service avec point d'ancrage	RAL 8017 Brun	<b>58.00</b>
18.760	<b>SDH-32-G</b>	Crochet de service avec point d'ancrage	RAL 7004 Gris	<b>58.00</b>
18.952	<b>SDH-32-R</b>	Crochet de service avec point d'ancrage	RAL 8004 Rouge	<b>58.00</b>
18.761	<b>SDA-35</b>	Point d'ancrage individuel de sécurité	Inox V2A	<b>56.00</b>

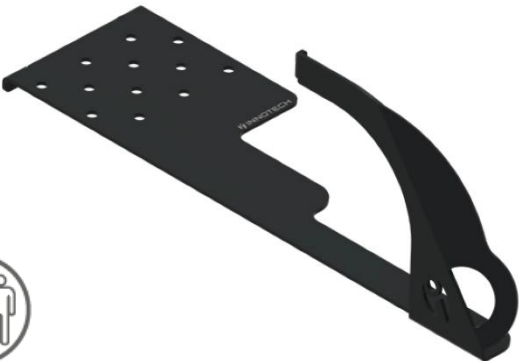

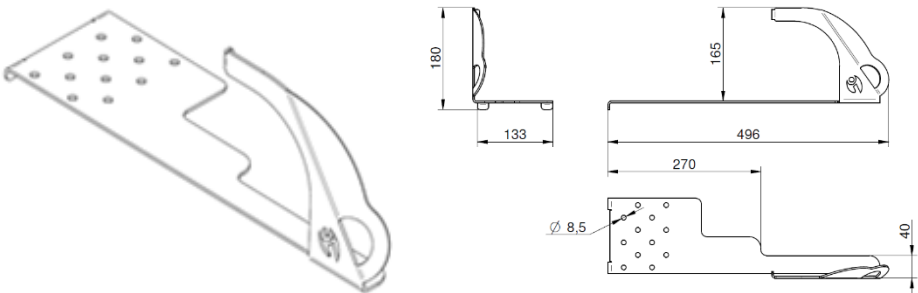
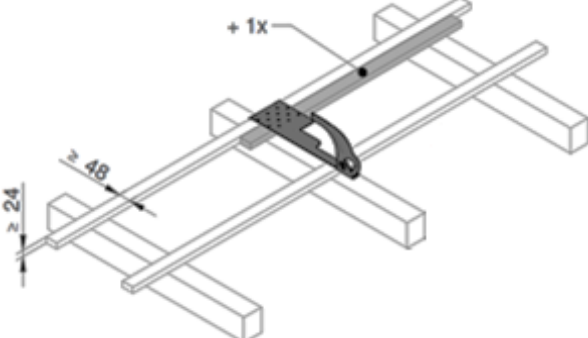
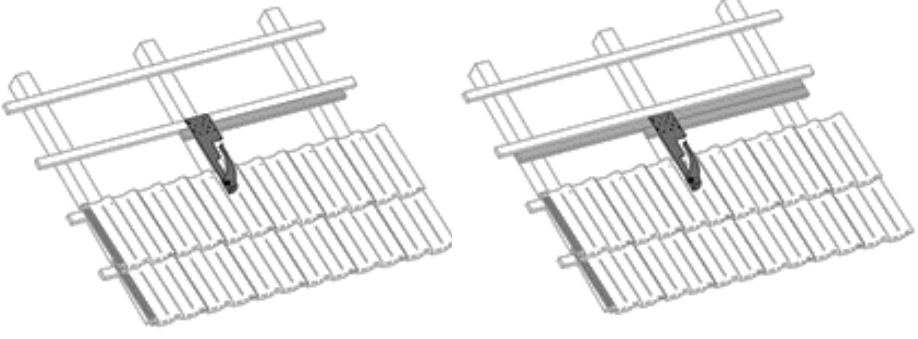

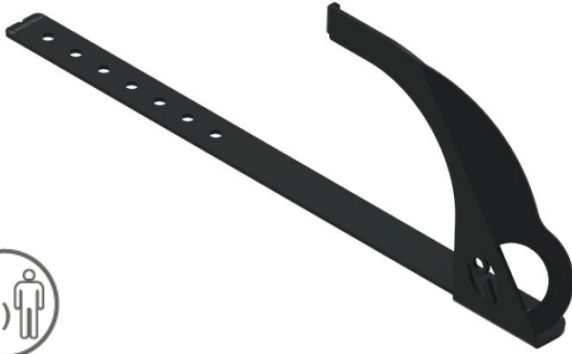
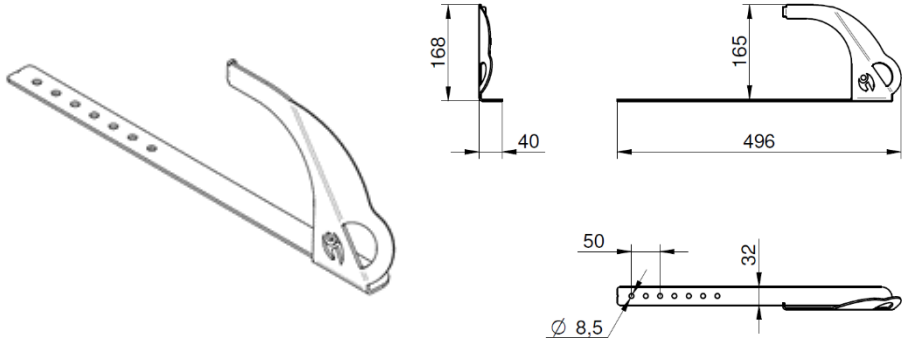
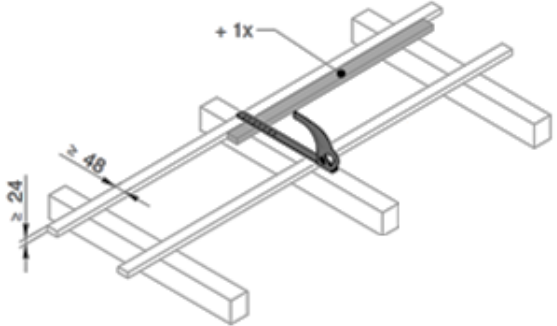
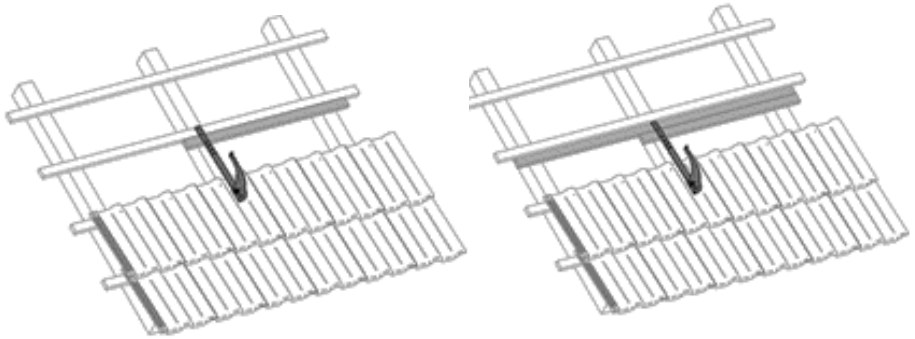

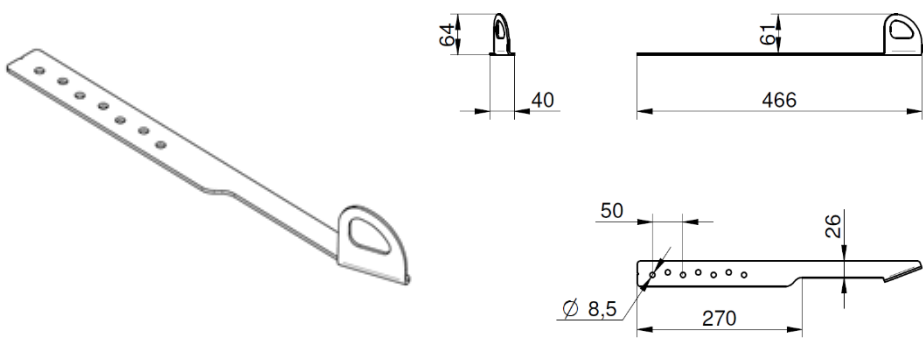
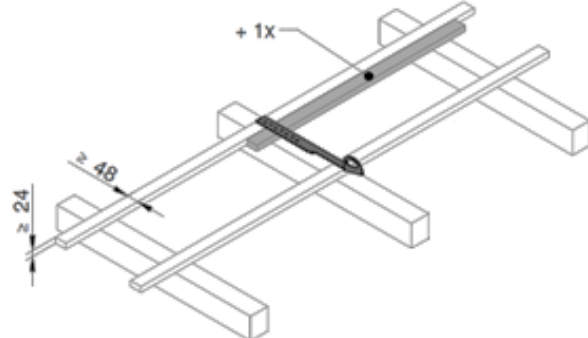
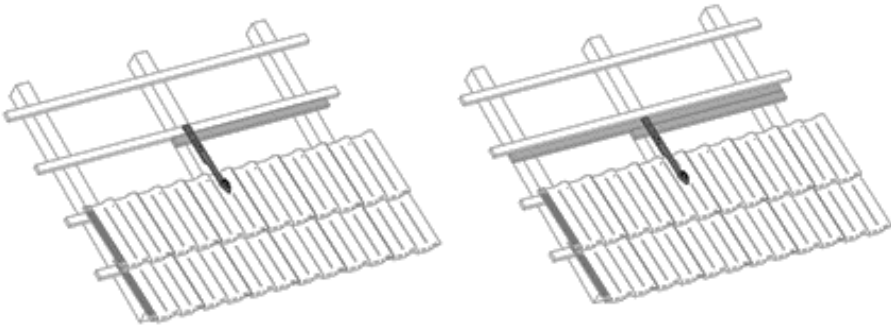

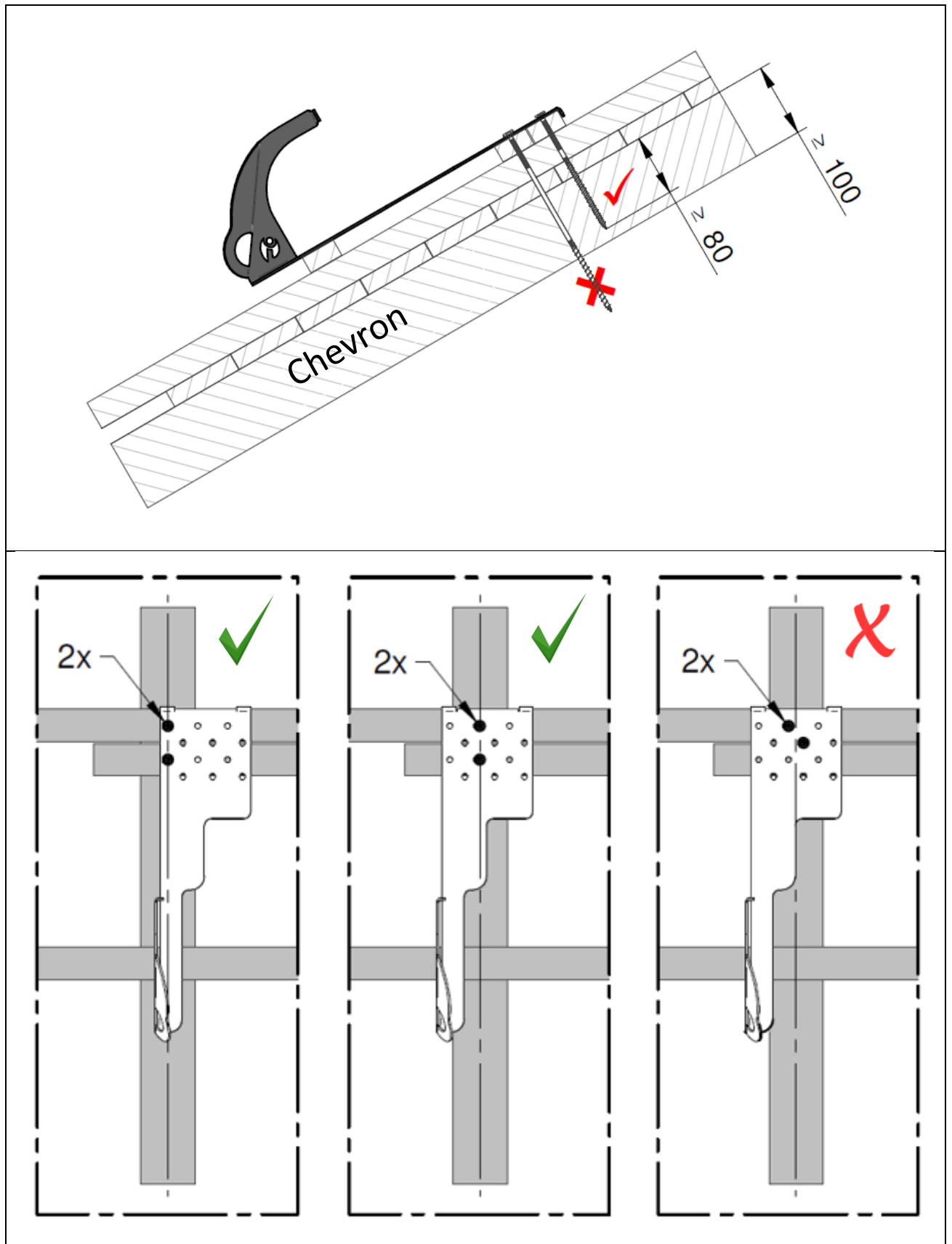

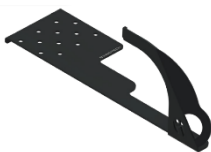

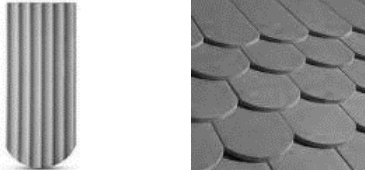









Anthracite, RAL 7021	SDH-31-A 	SDH-32-A 
Gris, RAL 7004	SDH-31-G 	SDH-32-G 
Brun, RAL 8017	SDH-31-B 	SDH-32-B 
Rouge, RAL 8004	SDH-31-R 	SDH-32-R 

SDH-31	  
Détail produit	
Mise en œuvre	
Mise en oeuvre	

<p>SDH-32</p>	 <p>EN 517:2006 TYP B</p> <p>1 (+1)</p>
<p>Détail produit</p>	
<p>Mise en œuvre</p>	
<p>Mise en œuvre</p>	

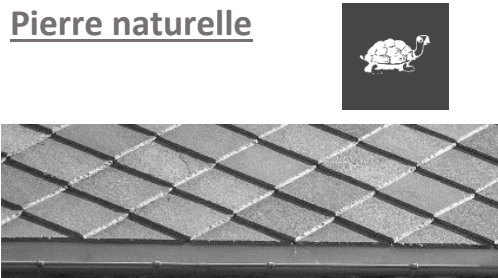
<p>SDA-35</p>	
<p>Détail produit</p>	
<p>Mise en œuvre</p>	
<p>Mise en oeuvre</p>	



	<b>SDH-31</b> 	<b>SDH-32</b> 	<b>SDA-35</b> 
<p><b>Tuile plate pose double</b></p> <p><b>NELSKAMP</b></p> 			
<p><b>Tuile mécanique pose simple</b> (Terre-cuite &amp; béton)</p> <p><b>NELSKAMP</b></p>  <p>Finkenberger      R 13 S</p>			
<p><b>Ardoise fibrociment double recouvrement</b></p>  <p><b>SVK</b> Experts in fibre cement</p>			
<p><b>Ardoise naturelle double recouvrement</b></p> <p><b>Rathscheck</b> SCHIEFER</p> 			
<p><b>Pierre naturelle</b></p> 			

# COUPON-RÉPONSE



E-mail : [info@isotosi.ch](mailto:info@isotosi.ch)

---

Si vous êtes intéressé, merci de cocher ce que vous désirez :

De la documentation et des échantillons

Merci de **me contacter** aux coordonnées ci-dessous

Autre :

\_\_\_\_\_

\_\_\_\_\_

---

ENTREPRISE

\_\_\_\_\_

PERSONNE DE CONTACT

\_\_\_\_\_

ADRESSE

\_\_\_\_\_

N° POSTAL

\_\_\_\_\_

LIEU

\_\_\_\_\_

N° DE TELEPHONE

\_\_\_\_\_

ADRESSE E-MAIL

\_\_\_\_\_

Version 07/2021